

## Dry type pillar fire hydrants (with break system)

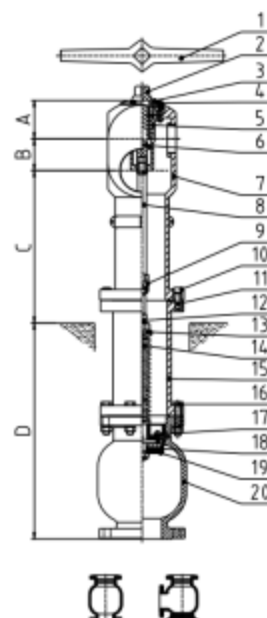

### SPECIFICATION

<b>Model</b>	FT-7S100		FT-7T150	
<b>Standard</b>	BS EN 14384			
<b>Working pressure</b>	16 BAR			
<b>Inlet</b>	DN100 with flange		DN150 with flange	
<b>Outlet</b>	2x2.5" BSP & 1x4" BSP, c/w couplings or landing valves			
<b>Dimension (mm)</b>	<b>A</b>	100		
	<b>B</b>	70		
	<b>C</b>	413		
	<b>D</b>	563	716	943
<b>Shell Material</b>	Ductile Iron			
<b>MOT</b>	≤ 125NM		≤ 125NM	
<b>MST</b>	≥ 250NM		≥ 250NM	
<b>Kv Value</b>	112.72 (2.5"outlet)		223.47(4"outlet)	
<b>Closing Direction</b>	Clockwise		Clockwise	
<b>Opening Turns</b>	11		11	
<b>Time for Draining</b>	≤ 10min		≤ 10min	
<b>Retained Water</b>	≤ 150ml		≤ 150ml	

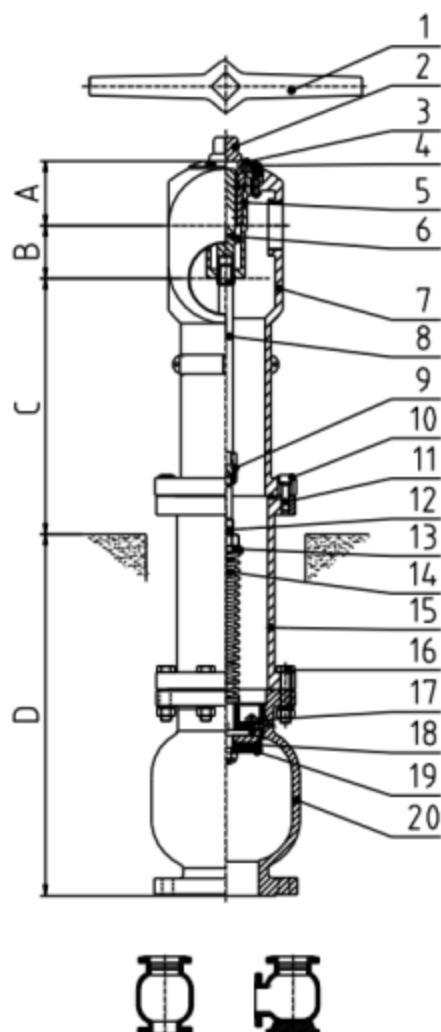

NO.	ITEM
1	OPERATING HANDLE
2	OPERATING NUT
3	COVER
4	COVER BOLT
5	BUSHING
6	CONNECTING STEM
7	UPPER BARREL
8	UPPER STEM
9	STEM COUPLING
10	PEDESTAL
11	BOLTS
12	LOWER STEM
13	SPRING SEAT
14	SPRING
15	LOWER BARREL
16	BOTTOM BOLT GASKET & NUT
17	AUTOMATIC DRAIN ASSEMBLY
18	SEAL
19	SEAL SEAT
20	BAND (90° or 180° type)

## FEATURES

Dry barrel design eliminates damage to the hydrant caused by freezing or corrosion of the upper part.

- ❖ Simple rugged construction and easy to maintain.
- ❖ Automatic drain system drains the water in the upper part when the main valve is closed thus avoiding damage caused by freezing.
- ❖ Externally sand blasted for smooth finish, painted red with electrostatic powder coating on the section above the ground and double coating of black bituminous paint on the section below ground, all paint thickness  $\geq 300\mu\text{m}$ .
- ❖ Optional: Barrel length extension kit in different lengths is available on request.
- ❖ Hydrants for non potable water systems.
- ❖ Flange according to customer requirements.
- ❖ Stem, steel or stainless steel for extra corrosion resistance.

## INSTALLATION

Pillar fire hydrant is an outdoor water supply facilities, for water supply to fire track or direct connection with fire hose or nozzle to fire fighting, is the essential facilities for outdoor fire service.

Pillar fire hydrants installation design, should be designed to consider the intersection area of the street, in the striking guarantee and does not affect pedestrians, driving position, while ensuring easy to maintenance and daily drainage, such as the curb on the sidewalk, nearby the storm drain and sidewalk's tree side.

## MAINTENANCE GUIDE

- ❖ Each month and before major holidays, should inspection the fire hydrants
- ❖ Debris removal around the operating nut.
- ❖ Set the special fire hydrant operating handle to the operating nut, check whether suitable and turn the operating handle, filling oil.
- ❖ Erase the plot rust on the outlet threads, and check the rubber gasket inside the cover is intact.
- ❖ Open the fire hydrants, check the water supply situation, put rust water and then close fire hydrants, and observe whether the water leakage, if identify problems need timely maintenance.
- ❖ Check the hydrants surface whether peeling paint, whether the rust, if any should be repaired